

**Item #
1000T-1CP-HH**

1000 Gallon Top Seam One Compartment with High Head Pump

Top View

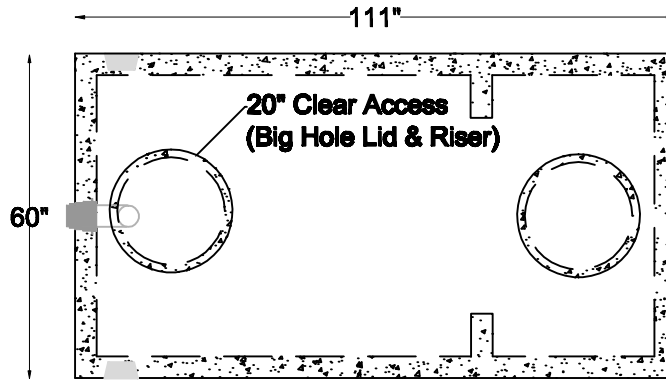

Section View

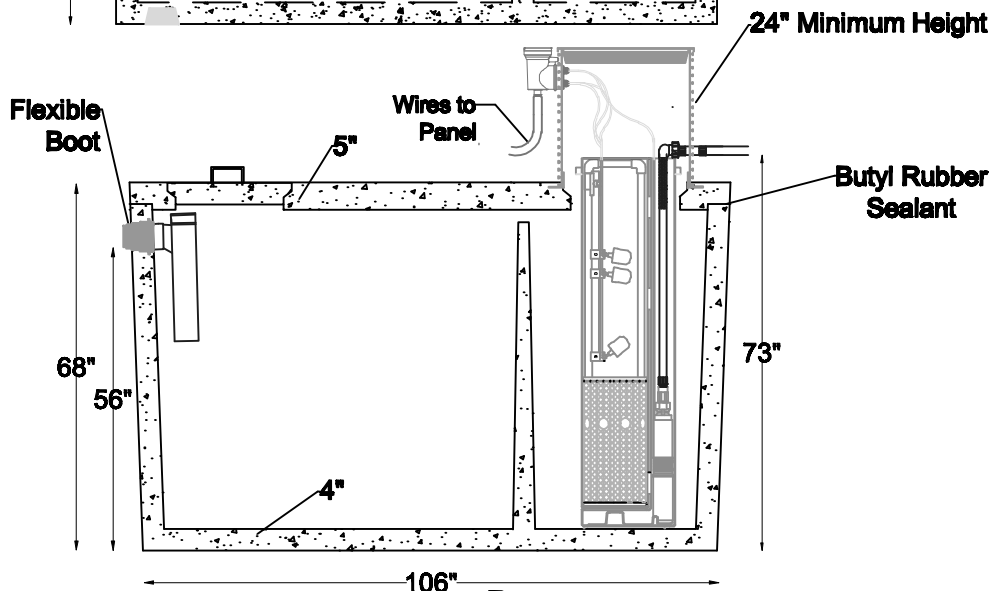

Tank:

***Meets ASTM C-1227 spec including C-1644-06 for resilient connectors**

- 4000 psi concrete
- Delivered complete with internal piping

Service contracts available for maintenance

Pump:

- Lowers TSS and improves effluent quality to field
- Easiest pump system to maintain on the market
- Complete installation (wiring, panel, mounting and start-up procedures)
- Complete warranty

Digging Specs	Invert		Dimensions			Net Capacity	Net Weight		
	Inlet	Outlet	Length	Width	Height		Lid	Tank	Total
11' Long x 7' Wide 56" below inlet invert	56"	73"	111"	60"	92"	1,042 gallons	2,620 lbs	8,915 lbs	11,735 lbs



Water & Wastewater

- Systems
- Products
- Service

(719) 395-6764

Fax: (719) 395-3727

Website: www.valleyprecast.com

Email: frontdesk@valleyprecast.com

28005 Co. Rd. 317
P.O. Box 925
Buena Vista, CO 81211