

**Item #
1000T-2CP-D2**

1000 Gallon Top Seam Two Compartment with 200 Series Dosing Siphon

Top View

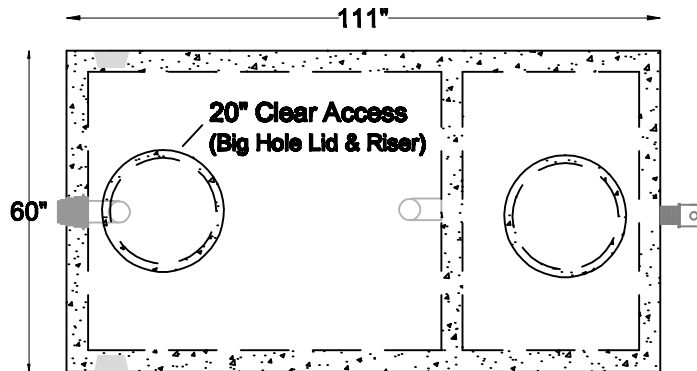

Section View

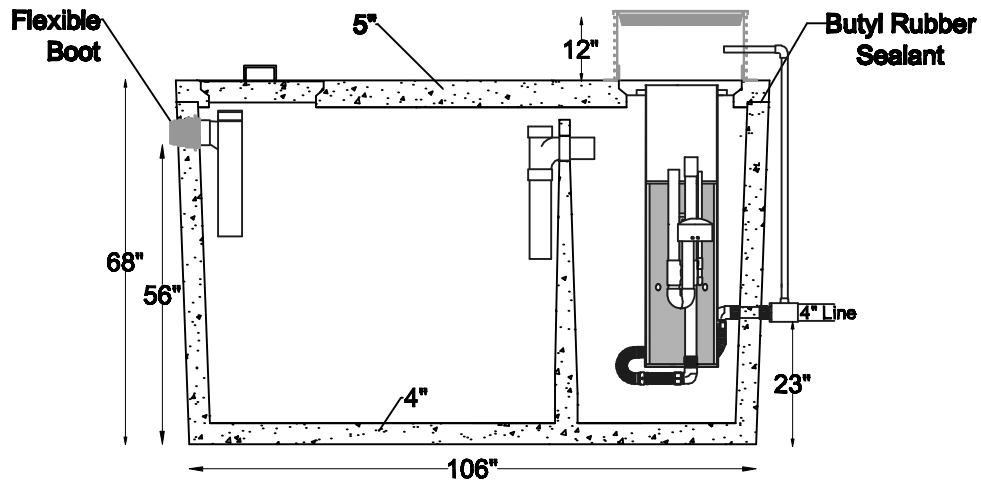

- Tank:**
- *Meets ASTM C-1227 spec including C-1644-06 for resilient connectors
 - 4000 psi concrete
 - Delivered complete with internal piping

- Siphon:**
- All siphons have removable screens
 - Low maintenance
 - No moving parts
 - Completely non-corrosive

Digging Specs	Invert		Dimensions			Net Capacity		
	Inlet	Outlet	Length	Width	Height	Inlet Side	Outlet Side	Total
11' Long x 7' Wide 56" below inlet invert	56"	23"	111"	60"	80"	687 gallons	323 gallons	1,010 gallons

Net Weight		
Lid	Tank	Total
2,260 lbs	9,380 lbs	12,050 lbs



**Water &
Wastewater**

- Systems
- Products
- Service

(719) 395-6764

Fax: (719) 395-3727

Website: www.valleyprecast.com

Email: frontdesk@valleyprecast.com

28005 Co. Rd. 317
P.O. Box 925
Buena Vista, CO 81211