

**Item #
1250T-2CP-LH**

1250 Gallon Top Seam Two Compartment with Low Head Pump

**Top
View**

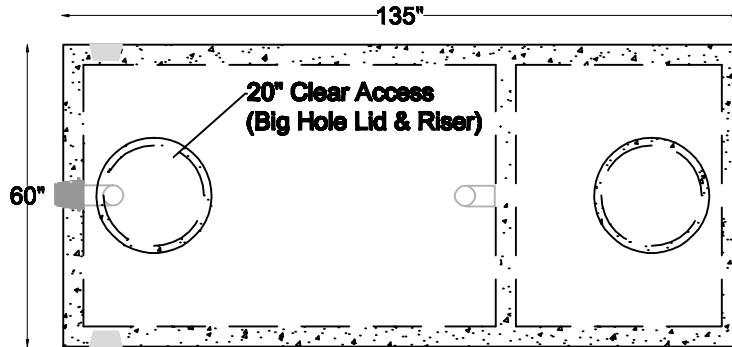

**Section
View**

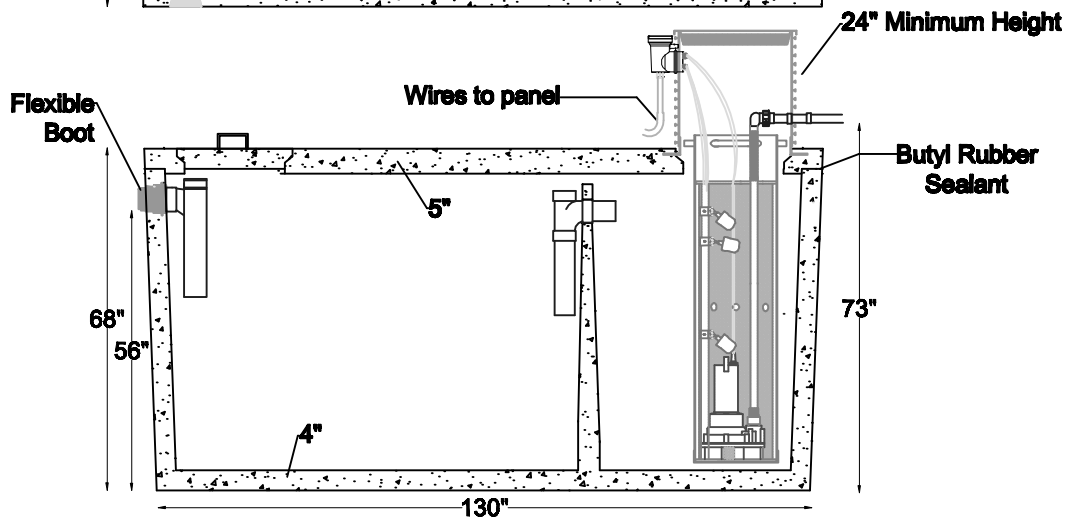

Tank:

***Meets ASTM C-1227 spec including C-1644-06 for resilient connectors**

- 4000 psi concrete
- Delivered complete with internal piping

Service contracts available for maintenance

Pump:

- Lowers TSS and improves effluent quality to field
- Complete installation (wiring, panel, mounting and start-up procedures)
- Complete warranty

Digging Specs	Invert		Dimensions			Net Capacity		
13' Long x 7' Wide 56" below inlet invert	Inlet 56"	Outlet 73"	Length 135"	Width 60"	Height 92"	Inlet Side 843 gallons	Outlet Side 416 gallons	Total 1,259 gallons

Net Weight		
Lid	Tank	Total
3,120 lbs	10,880 lbs	14,200 lbs



**Water &
Wastewater**

- Systems
- Products
- Service

(719) 395-6764

Fax: (719) 395-3727

Website: www.valleyprecast.com

Email: frontdesk@valleyprecast.com

28005 Co. Rd. 317

P.O. Box 925

Buena Vista, CO 81211