

1500 Three Compartment with High Head Pump, Flow Inducer

Item # 1500T-3CP-P-FI **(2000 Gallon Total Volume)**

Top View

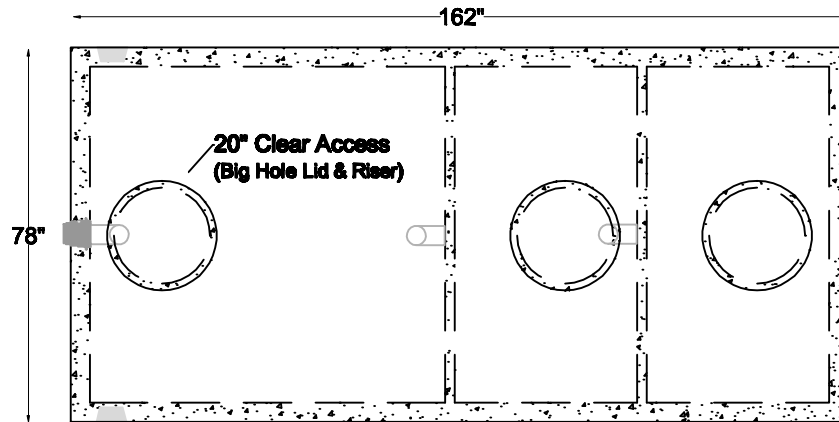

Section View

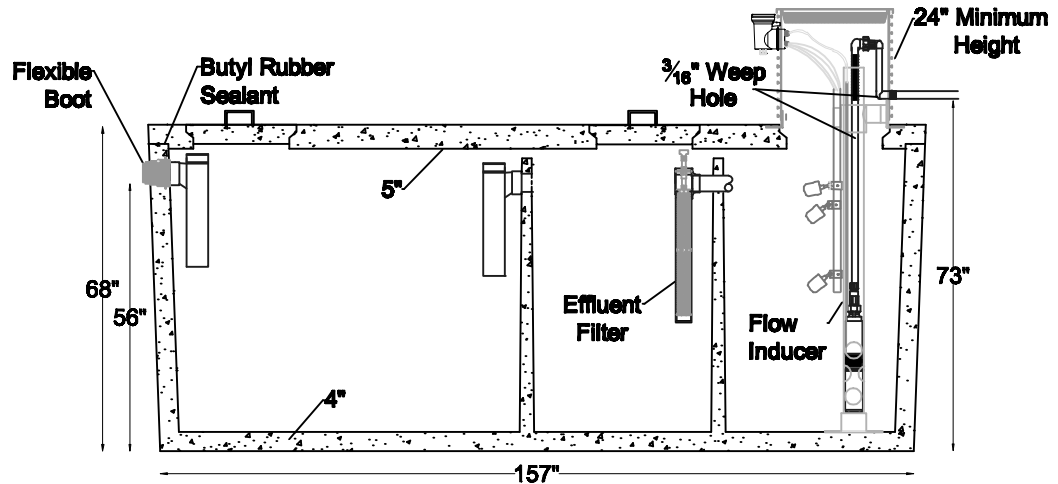

Tank:

***Meets ASTM C-1227 spec including C-1644-06 for resilient connectors**

- 4000 psi concrete
- Delivered complete with internal piping
- PVC or concrete riser available on 1st or 2nd compartment
- Limited availability areas

Digging Specs	Invert		Dimensions		
	Inlet	Outlet	Length	Width	Height
15' Long x 8' Wide 56" below inlet invert	56"	73"	162"	78"	92"

Net Capacity				Net Weight		
Inlet Side	Middle	Outlet Side	Total	Lid	Tank	Total
1,016 gallons	505 gallons	505 gallons	2,026 gallons	5,420 lbs	16,400 lbs	21,820 lbs



Water & Wastewater

- Systems
- Products
- Service

(719) 395-6764

Fax: (719) 395-3727

Website: www.valleyprecast.com

Email: frontdesk@valleyprecast.com

28005 Co. Rd. 317
P.O. Box 925
Buena Vista, CO 81211