

**Item #
1500T-GI**

1500 Gallon Grease Interceptor H-20 Load Rated

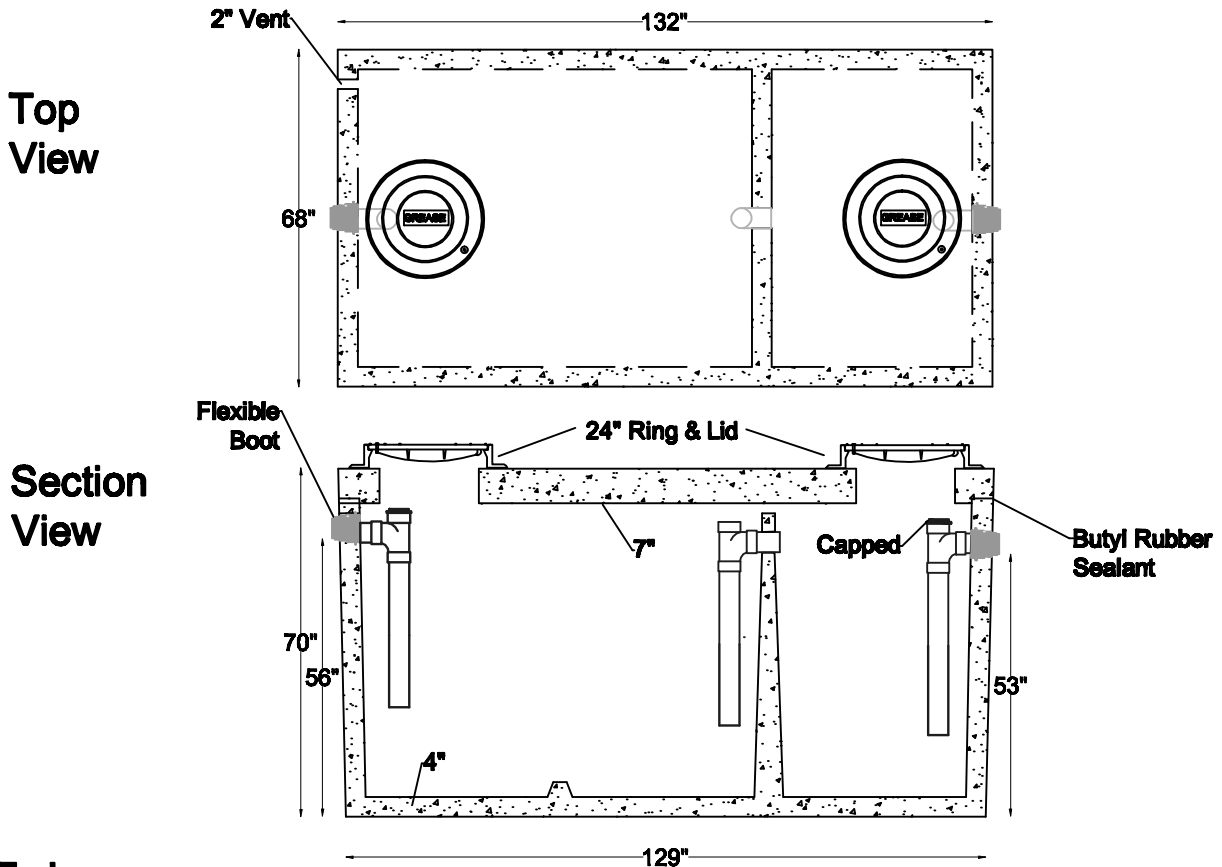

Tank:

***Meets ASTM C-1613 spec for Grease Interceptor including the new C-1644-06 for resilient connectors**

- ASSHTO H-20 Load Rated
- 4000 psi concrete
- Includes Cast Iron Ring and Locking Aluminum Lid stamped "Grease"
- Complete with internal piping
- Vents to atmosphere, T's capped

Benefits:

- More efficient grease removal than kitchen units
- Odor & mess eliminated from kitchen

*Optional concrete grade rings available for an additional charge:
2", 4", or 6"*

Digging Specs	Invert		Dimensions		
13" Long x 8" Wide 56" below inlet Invert	Inlet 56"	Outlet 53"	Length 132"	Width 68"	Height 70"

Net Capacity			Net Weight		
Inlet Side 1,002 gal	Outlet Side 503 gal	Total 1,505 gal	Lid 4,860 lbs	Tank 11,180 lbs	Total 16,040 lbs



**Water &
Wastewater**

- Systems
- Products
- Service

(719) 395-6764

Fax: (719) 395-3727

Website: www.valleyprecast.com

Email: frontdesk@valleyprecast.com

**28005 Co. Rd. 317
P.O. Box 925
Buena Vista, CO 81211**