

Item#  
BRVBULK

# Bull Run™ Valve & Key



The Bull Run Valve™ is designed to split flows to septic fields or systems. In addition to the advantages of longer life and easier installation it is the most public health safe alternating device available for wastewater disposal applications. The use has absolutely no contact with wastewater due to the valve's leak-proof and external operating characteristics. The change over from one drainage field to another can be accomplished in less than a minute by simply turning the valve without digging or contact with wastewater.

SIZE: 4" Valve Ports  
MATERIAL: PVC  
WEIGHT: 2 ½ Pounds  
POSITIONER: Manual with  
Internal Stop

- 1) Valve Body
- 2) Direction Control Handle
- 3) Valve "IN" Port
- 4) Valve "OUT" Port
- 5) Riser Tube Connection
- 6) Positioning Shape  
Indicator Number

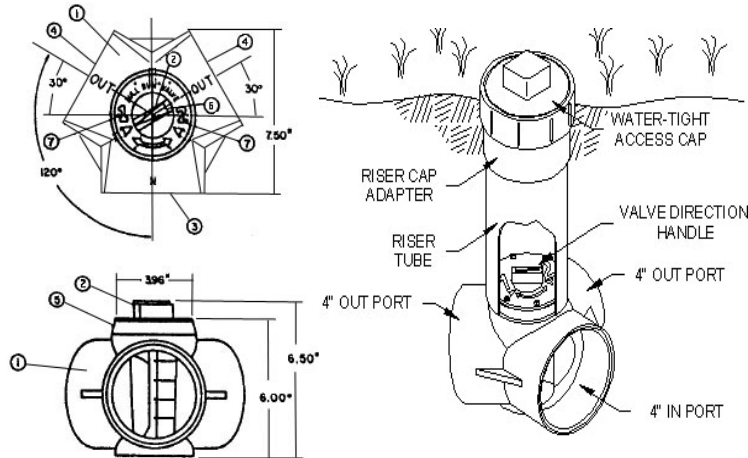

The Bull Run Valve is available in 4" sch 40 PVC and is suitable wherever septic disposal systems are used - in commercial, industrial, and residential applications.

**OPERATING THE VALVE**  
The direction control handle should be rotated periodically to direct effluent to one or the other of two septic fields. After removing the screw cap at the top of the riser tube, the valve handle can be turned with the valve key furnished.

## INSTALLATION INSTRUCTIONS DIRECT BURIAL

The valve is designed to be buried directly in the pipe trench requiring no concrete or hold down strap installation. The valve must be installed with the septic tank effluent line connected to the valve port marked "IN". The valve ports marked "OUT" are connected to each half of the drainfield.

## ADAPTABLE TO VARIOUS PIPES

Each valve port connection is a 4" schedule 40 female slip connection. The riser tube connection is a 4" schedule 40 male slip connection. Use ample PVC, ABS, or multi-purpose glue to form a water-tight joint. Any of the following can be used to connect to the Valve:

- 1) Schedule 40 PVC or ABS Pipe
- 2) Adapter Bushing (Dwv Hub to sewer & drain spigot)
- 3) ASTM 2729 (Schedule 30)
- 4) Bell End Of ASTM 2729 (Schedule 30) Pipe

## SAMPLE VALVE SPECIFICATION

A non-corrosive alternating valve shall be provided with 4" schedule 40 female connections. The valve plug shall be non-removable, watertight and externally operated. The valve shall be provided with an internal stop mechanism for positioning the plug, and the plug shall be non-jamming when turning from stop. There shall be no metal parts in contact with the wastewater.

The inlet and outlet ports shall be clearly labeled for easy installation and the position of the valve shall be clearly indicated on the top of the valve. At no time shall the operator have contact (physical or visual) with the wastewater. The valve shall be installed in such a manner as to be easily accessible from the ground surface and operated with the standard water meter key provided. Simple instructions for use and maintenance, printed on durable material, shall be supplied along with each device. The valve shall be the Bull Run Valve.

## OPERATION BY WATER METER KEY

A riser cap adapter, a water-tight access cap and valve key are provided. The valve should be buried at such a depth as to allow easy access and operation from the ground surface with the standard water meter key provided.

## PUMP SYSTEMS

Effluent pumps can be used to dose the drainfield. The top of the valve is o-ring sealed and pressure tight under normal effluent pump operating conditions. Maximum pressure 25 psi. The internal plug is tapered to match the valve body seating ribs. This seating mechanism will prevent bypass under minimum head pressure conditions.



Water &  
Wastewater

- Systems
- Products
- Service

(719) 395-6764

Fax: (719) 395-3727

Website: <http://valleyprecast.com/>

Email: [frontdesk@valleyprecast.com](mailto:frontdesk@valleyprecast.com)

28005 County Road 317  
P.O. Box 925  
Buena Vista, CO 81211